



More freedom in the kitchen

The 6000 Bridge Extractor Hob combines an induction hob to fit a 60cm cabinet, with a powerful built-in extractor for optimal air flow. It also has a Bridge function, allowing you to combine two cooking zones into one for larger cookware.

Product Benefits & Features



The Bridge Extractor Hob. For greater kitchen freedom

The Bridge Extractor Hob combines an induction hob for 60cm cabinets with a powerful built-in extractor for optimal airflow. Its Bridge function merges two cooking zones at the same temperature, ideal for bigger pots or plancha grill.



OdourClean Plus Carbon Filter. Clean and re-use multiple times

The Grease Filter and OdourClean Plus Carbon Filter are easy to clean in the dishwasher, so your kitchen air stays fresh, and your fan runs at its best for longer. Carbon filters can after cleaning be regenerated up to 8 times for extended life up to 3 years.

*The stated lifespan is an estimate based on internal testing. Performance may vary depending on individual usage patterns and conditions; actual lifespan may be shorter or longer.



Modern, matt black beauty. Our most scratch-resistant surface

A modern design statement at the heart of your kitchen. The SaphirMatt® hob's matt black finish enhances its minimalist aesthetic. Made with our most scratch-resistant, fingerprint-resistant surface for lasting, effortless beauty.



4 Individual Zone Controls. Unlimited cooking options

4 Individual Zone Controls, with 9 power levels, allow you to Individually control 4 different cooking areas and set separate timers for each. Other functions include power boost, active touch, child lock and automatic extractor control.



Automatic Extractor Control. Adjusts as you cook

Automatic Extractor Control allows you to focus on what matters – cooking. The hob will automatically switch on and adjust the extraction level according to your cooking activities, keeping your kitchen fresh and hands free.

- ComboHob: 2-in-1 combination of hob and extractor fan.
- SaphirMatt® hob is up to four times more scratch-resistant.
- Residual heat indicators: Show when the hob surface is still hot after use.
- PowerBoost: Gives an instant increase in temperature allowing water to boil in less than 90 seconds.
- Child lock safety function.
- Auto safety switch off: The power automatically turns off if a cooking zone is left on for too long.
- Bridging function: Combines 2 cooking zones allowing flexibility for any size pan.
- Inverter motor
- Grease filter indicator.
- Charcoal filter indicator.
- Grease filter type and number: Aluminium mesh, 2
- Minute minder
- EcoTimer™: Saves energy by using the residual heat from the hob, turning off the cooking zone before the end of your timer to boost efficiency.
- Automated extraction: Auto mode adjusts the extractor fan based on hob temperature changes, so you can focus entirely on cooking.
- Pause functionality allows you to take short breaks without losing your cooking settings.
- Extraction mode: A ducting kit is attached to the hood to extract cooking vapours externally, keeping the kitchen free from odours.

Product Specification

Frame Type	Statement Frame Matt Black	Recirculated Extraction Rate - Min/Max/Intensive (m³/h)	250/480/585
Dimensions (mm) (WxD)	830x520	Ducted Noise Level - Min/Max/Intensive (dB)	50/66/69
Built-in Dimensions (mm) (HxWxD)	225x750 - 780x490	Extraction Type - Recirculation	Yes
Air Outlet (mm)	220	Extraction Type - Ducted	Yes
Grease Filter Type	Aluminium mesh	Hob2Hood Connection	Yes
Number of Grease Filters	2	Net Weight (Kg)	17.8
Aperture Cut Out (mm)	5	Gross Weight (Kg)	22.2
Energy Rating	A+		
Fluid Dynamic Efficiency Rating	A		
Grease Filter Efficiency Rating	B		
Motor Type	Brushless		
Cord Length (m)	N/A		
Bar Code	7333394075815		
Product Number (PNC)	Exclusive KR Partner		
Plug or Hardwired	Hardwired connection only		
Left Front - Power/Diameter	2300/3200W/210mm		
Left Rear - Power/Diameter	2300/3200W/210mm		
Right Front - Power/Diameter	1400/2500W/145mm		
Right Rear - Power/Diameter	1800/2800W/180mm		
Number of Cooking Zones	4		
Series	6000		
Hob Type	Induction Extractor Hob		
Ducted Extraction Rate - Min/Max/Intensive (m³/h)	650/550/270		

PSGBHH240DE00001

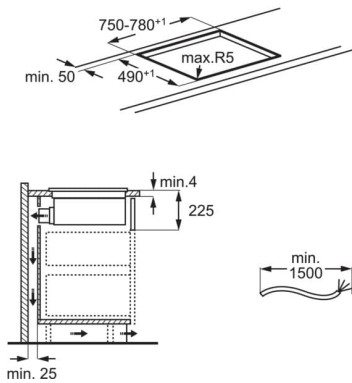

PSGBHH240DE00008

